



PRIMO® XL PLUS

Comfort Seat with
Pneumatic Suspension



CAPITALseating

www.capitalseating.co.uk

tel: +44 (0)116 216 9910 | email: grammer@capitalseating.co.uk



GRAMMER

TECHNICAL DATA

PRIMO® XL PLUS

The Primo XL Plus excels with its low-constructed pneumatic suspension, which ensures comfortable driving. The 110 mm suspension travel gently compensates for even the roughest vibrations and jolts. It can be conveniently set to the operator's weight by pressing a button. A narrow yet comfortable upper seat section upholstered in artificial leather makes for fatigue-free work.



Pneumatic
Suspension



Mechanical
Lumbar
Support



Manual
Weight
Adjustment

Features ● Standard ○ Optional

	PRIMO® XL PLUS
Article no. imitation leather Compressor 12V	1247727
Shock absorber nonadjustable	●
Suspension	●
Pneumatic suspension with compressor	●
Suspension stroke 110 mm	●
① Weight adjustment 45 - 170 kg, pneumatic	●
② Fore/aft adjustment 210 mm	●
③ Lumbar support mechanical	●

	PRIMO® XL PLUS
④ Adjustable backrest angle	●
⑤ Restraint system	●
Seat cushion width	480 mm
Operator presence switch (OPS)	●
OPTIONAL FEATURES	
⑥ Document box	○
⑦ Armrests height-adjustable	○
Fore/aft isolator*	○
⑧ Backrest extension	○
⑨ Seat heating	○

* Fore/aft isolator not for earth-moving machinery

Measurements (installation dimensions)

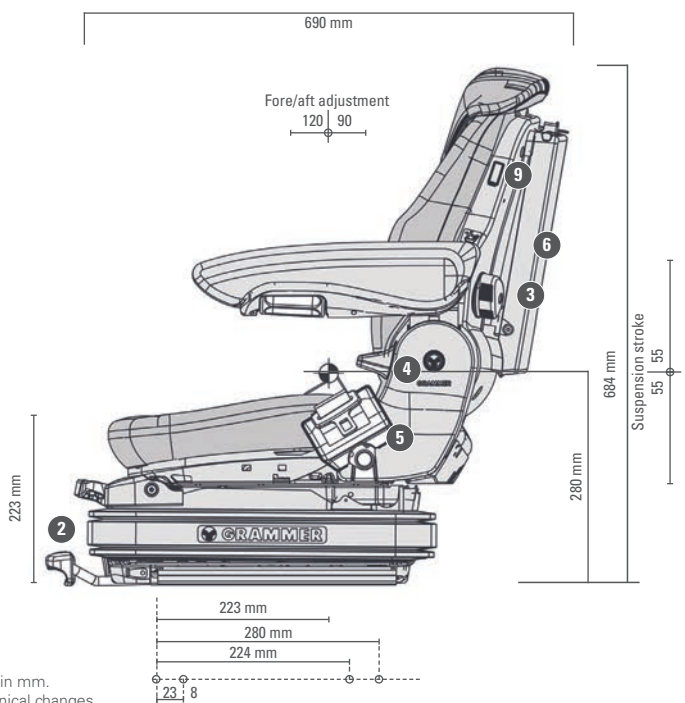
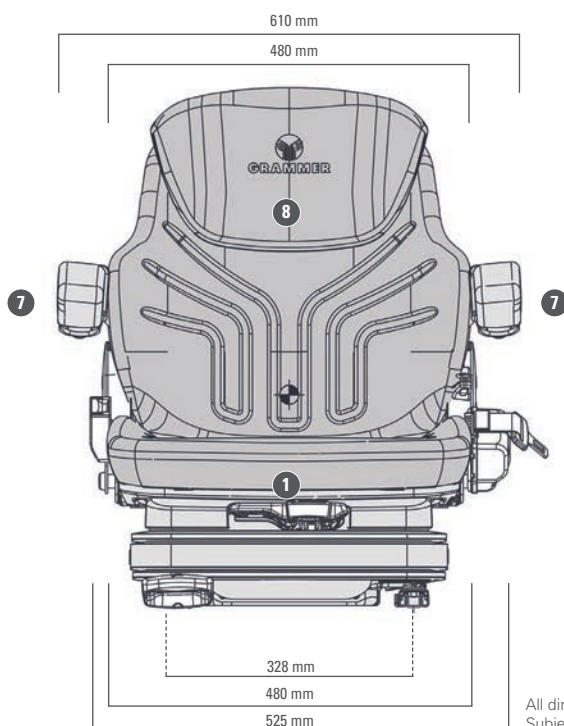

All dimensions in mm.
Subject to technical changes.