



PRIMO[®] PROFESSIONAL

Compact Seats with
Extremely Low-Frequency
Pneumatic Suspension



CAPITALseating

www.capitalseating.co.uk

tel: +44 (0)116 216 9910 | email: grammer@capitalseating.co.uk



GRAMMER

TECHNICAL DATA

PRIMO® PROFESSIONAL

This innovative compact seat features a pneumatic suspension with a very low resonant frequency, making it ideal for tractors with limited space for installation. It can be quickly and flexibly set to different heights and operator weights using a single control. A lumbar support ideally protects the vertebrae of the lower back to reduce the risk of injury to the spinal disks. The backrest is asymmetrically shaped to provide more elbow room on the right and full back support on the left.



Pneumatic Suspension



Low-Frequency Suspension



Mechanical Lumbar Support



Manual Weight Adjustment



Fore/Aft Isolator

Features ● Standard ○ Optional

	Primo® Professional S	Primo® Professional M
Article no. fabric	1291748	1291749
Article no. imitation leather	1212687	1212688
Shock absorber	●	●
① Suspension		
● Pneumatic with 12V compressor	●	●
● Low-frequency suspension	●	●
② Weight adjustment 45–170 kg	●	●
③ Height adjustment 60 mm	●	●
④ Fore/aft adjustment 210 mm	●	●
⑤ Lumbar support, mechanical	●	●
⑥ Adjustable backrest angle	●	●

	Primo® Professional S	Primo® Professional M
⑦ Seatback extension Insertable	●	●
Seat cushion width	400 mm	450 mm
OPTIONAL FEATURES		
Document box	○	○
⑧ Armrests, adjustable angle 60 mm x 320 mm	○	○
⑨ Fore/aft isolator	○	○
⑩ Restraint system Duo-sensitive retractable belt	○	○
Seat heating	○	○
Operator presence switch (OPS)	○	○

Measurements (installation dimensions)

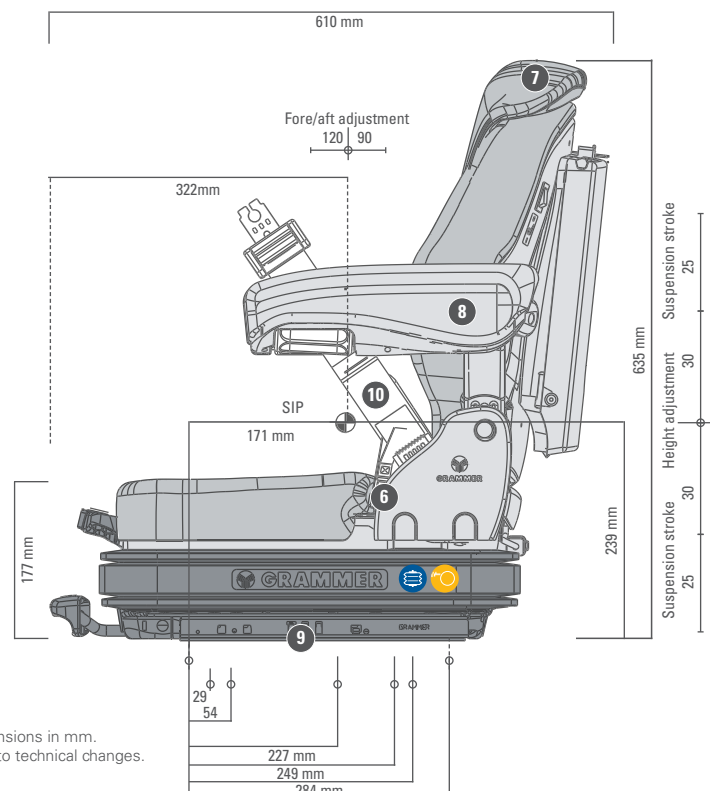
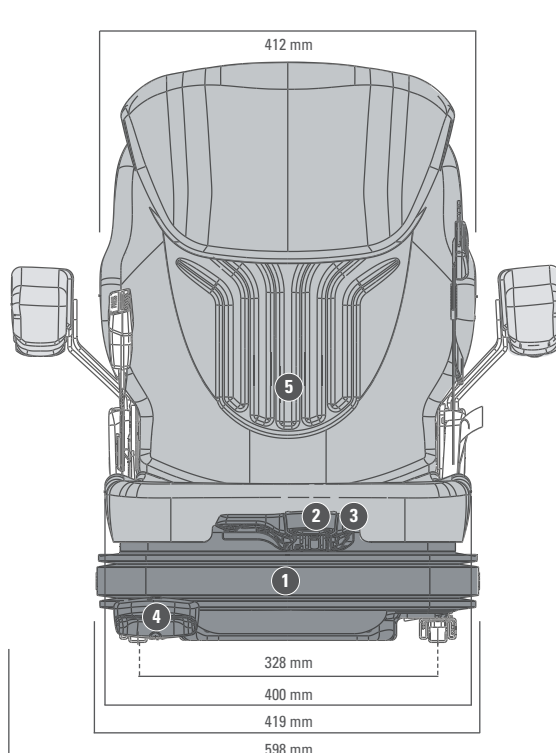

All dimensions in mm.
Subject to technical changes.