



GRAMMER BUS PASSENGER SEATS





BACK ON ROAD

Our vision is to become a full-line supplier of bus seats.

As a full-line supplier of passenger and driver seats for trains, we offer a complete range of seats for high distance and premium, regional and intercity and city traffic.

Now we are also widening our bus seat range step by step. Our vision is to likewise become a full-line supplier of driver and passenger seats for buses in all segments.

We offer individual solutions addressing all customer requirements and set standards in comfort, ergonomics, design, modularity and safety with our products.







CORE COMPETENCES

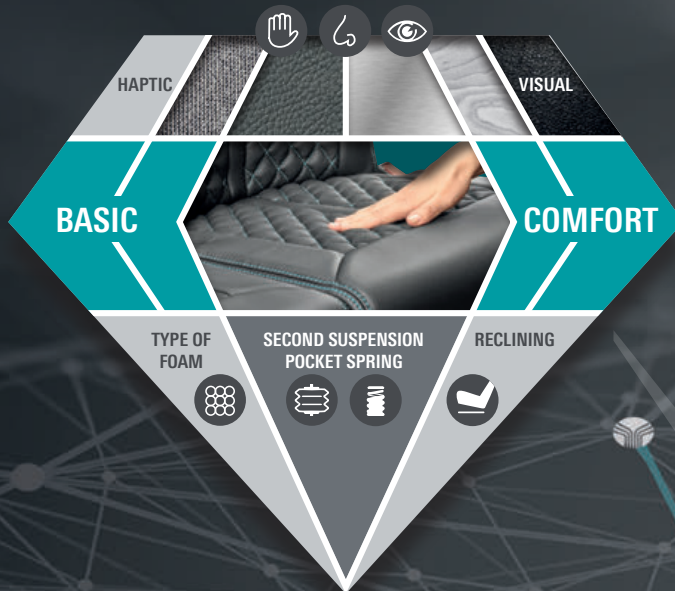

PERCEIVED QUALITY

Product quality – for all the senses.
For a product to be really good, our customers must be able to perceive it with all their senses.

We offer seats in all levels of comfort.

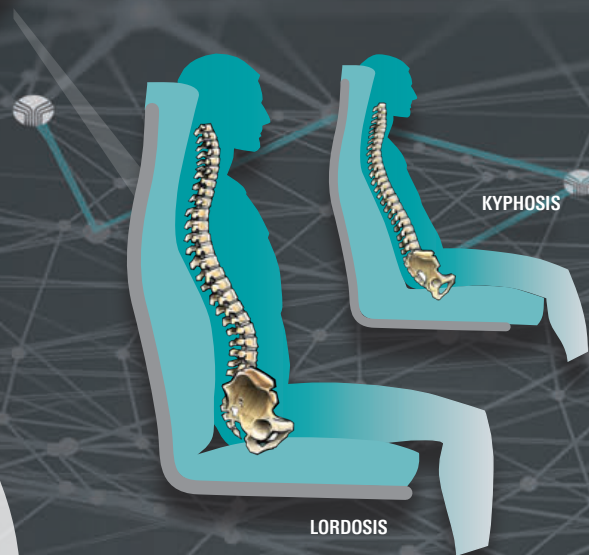

ERGOMECHANICS

As trend setters in ergonomics, safety and comfort, we have been working closely with scientists, universities and research institutions for many decades.

Ergomechanics is the key word for seats meeting the highest requirements. By linking ergonomics and biomechanics, we are able to design seats that feature a sophisticated suspension system for minimizing vibration strain for passengers.

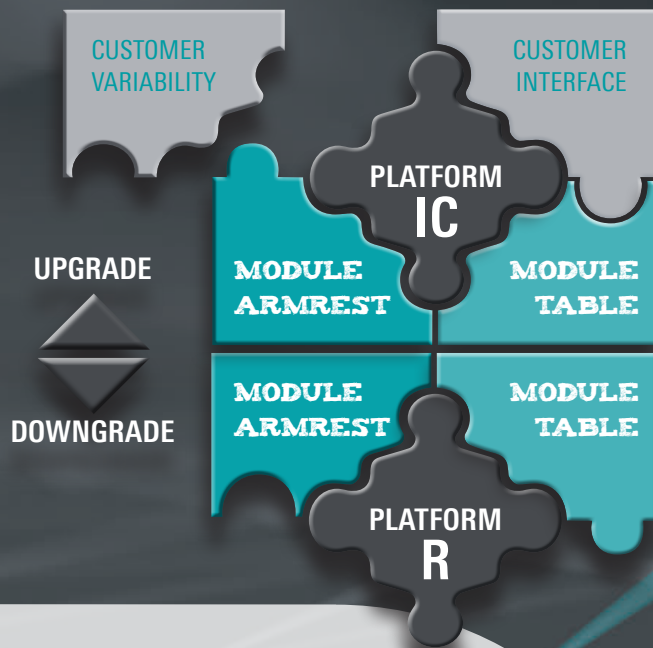

MODULAR DESIGN

Individual solutions for all types of use. Our modular designs combine top functionality with extensive adjustability and a modern look. Discover the countless possibilities offered by our modular designs with their numerous comfort upgrades and downgrades.

Whether you are looking for a simple or a luxurious solution, we offer individual, bespoke solutions in all segments.



CONNECTIVITY

Whether it's for work or entertainment, seats offer numerous opportunities for integrating technical applications such as.

- > Power sockets
- > USB
- > Charging facilities
- > Tablet holder
- > Table for laptop





CITY3000

The seat for city traffic

Lean lines, simple and attractive design.
The City3000 offers top quality for short routes
characterized by large numbers of
different passengers

Further variants:

- > PRM seats
- > Parent-and-child seats



Grab handle



Armrest



Hip support

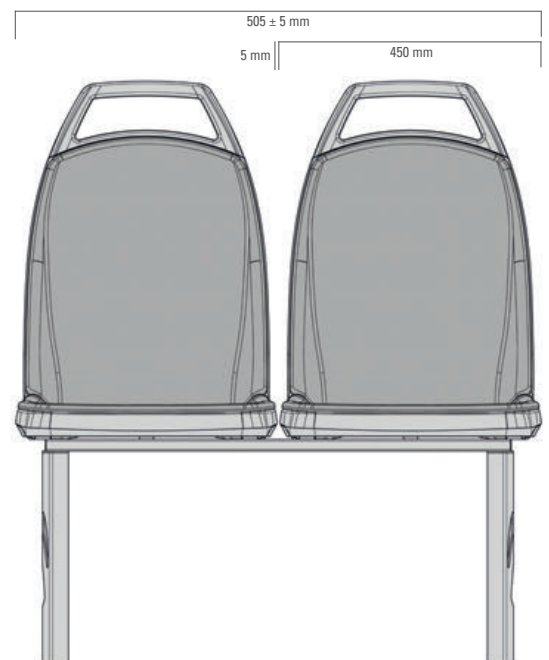
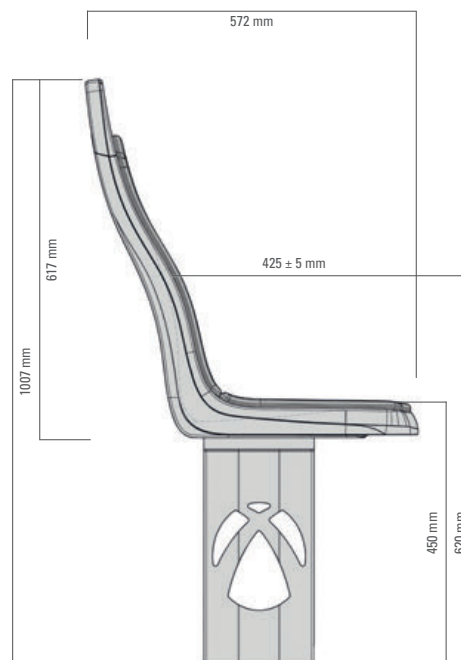

> Approved bus classes:





INNERCITY3000

The new seat for city traffic

The Innercity3000 for city traffic combines attractive design with a modular lightweight concept: With a width of 450 mm its total weight stays under 5 kg. The seat is manufactured with resource-saving and easy-to-recycle plastic material. It offers numerous customizable design options such as color, thickness of the upholstery or the integration of logo elements. The ideally shaped grab handle ensures more passenger safety. A USB-port, lightning elements or a holding-function-button can be integrated in the seat.



Haltegriff

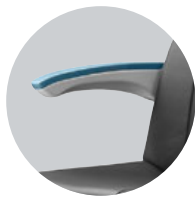

Armlehne



Hip-Rest

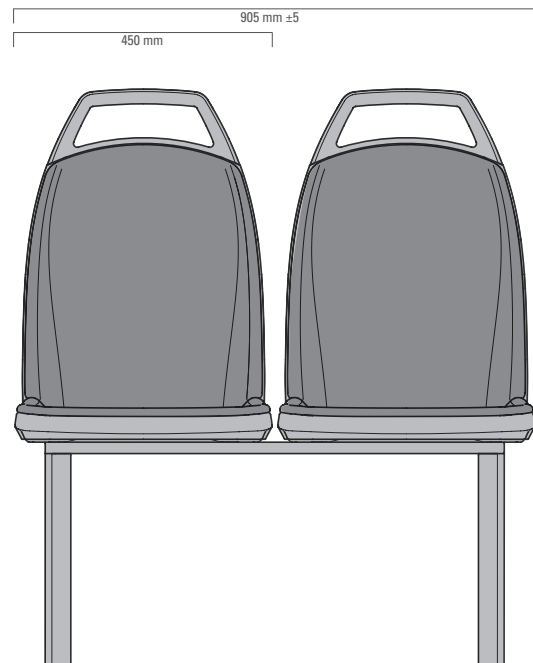
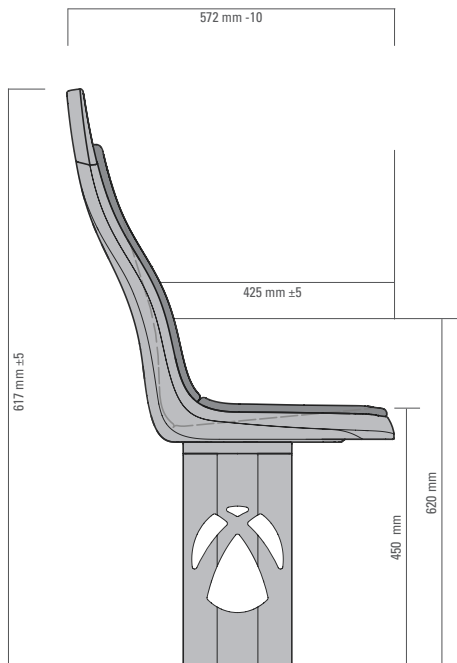

USB



Nachhaltigkeit

> Approved bus classes:





INTERCITY3000

The flexible seat for coaches

The INTERCITY3000 coach seat offers maximum flexibility. Depending on requirements, it comes in a functional basic version or in an exclusive design. There are almost no limits to the options available. The premium-quality coach seat can be fitted with all sorts of accessories such as seat numbers, folding tables, luggage nets, foot rests or premium-comfort headrests.

The INTERCITY3000 is the all-rounder for travel and long-distance business.



Coat hook



Side part



Mobile phone table

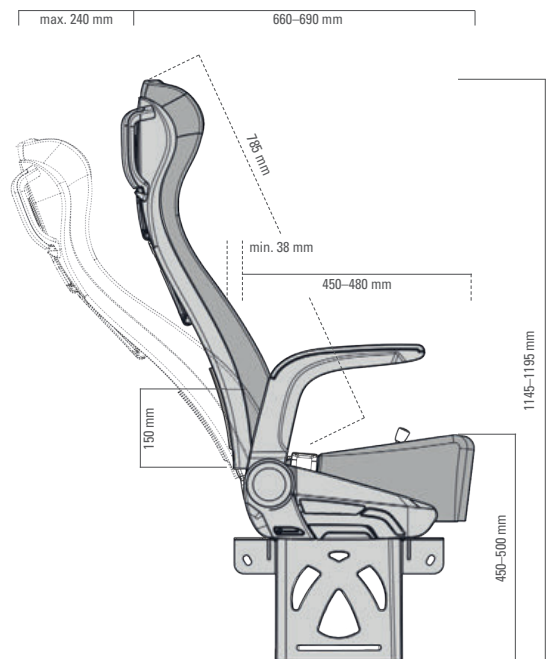
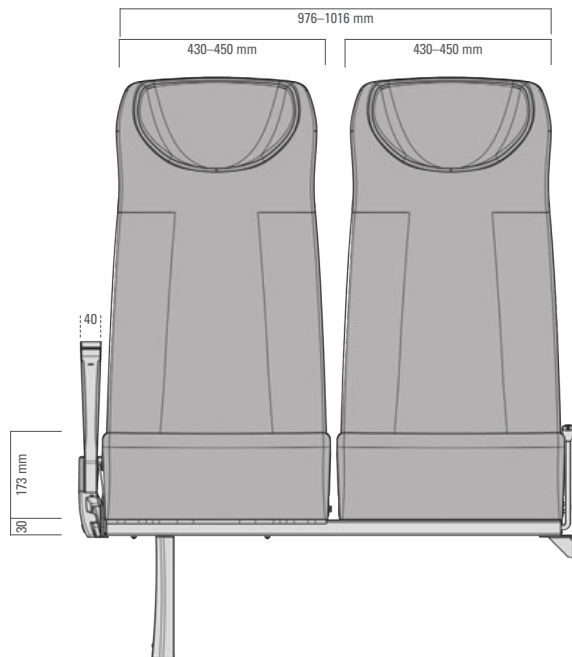

> Ergonomic seat contour for voyages of over 2 hours

> Approved bus classes:





PREMIUM3000

High End Quality Seat

The electronically adjustable P3000 meets all the requirements of discerning passengers. With its attractive modern design and numerous adjustments options, it allows passengers to travel and work comfortably, conveniently and in a relaxed manner. The seat, back and head cushions as well as the leg rest are electronically adjustable. With its extensive range of equipment including USB connections, power sockets and the renowned GRAMMER ergomechanics philosophy, it offers maximum comfort for passengers. In addition, the memory function allows the seats to be adjusted to a certain position to facilitate cleaning etc.



220V Power Socket



Legrest



Folding Table

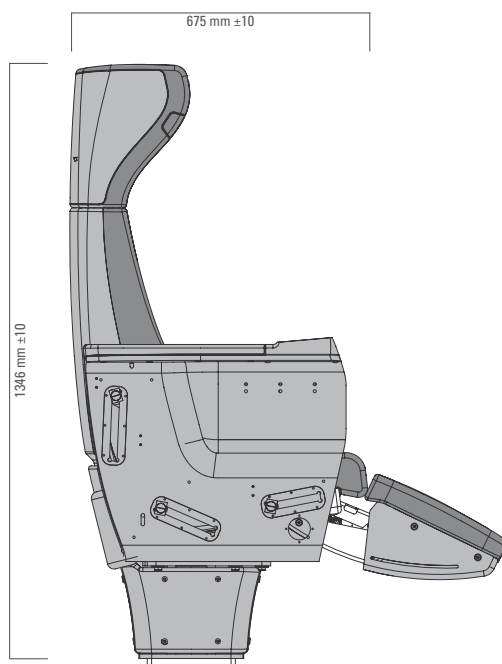
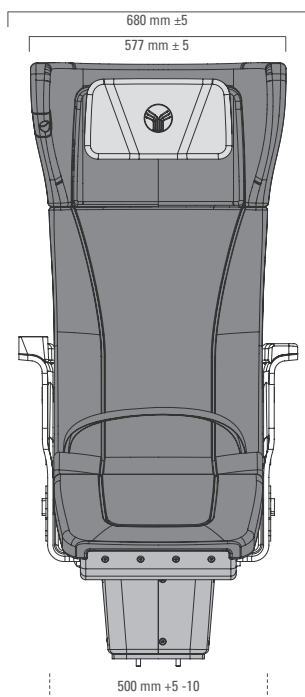

- Ergo-mechanics
- Massage system
- Seat heating
- Active climate control
- Headrest
- Legrest
- Foam
- Light
- 230V Power Socket
- USB
- Folding table
- Storage compartment

> Ergonomic seat contour for voyages of over 2 hours

> Approved bus classes:





PRODUCT OVERVIEW

Basic Features	CITY3000	INNERCITY3000	INTERCITY 3000
General			
2-point safety belt			●
3-point safety belt with lateral adjustment			○
Seat cushion in short and narrow design			○
Seat cushion in long and extra narrow design			○
Seat cushion in long and narrow design			○
Seat cushion in long and wide design			●
Seat cushion suspension			○
Backrest			
Seat without backrest and / or seat padding	○		
Backrest rigid	●		○
Backrest adjustable			●
Luggage net			●
Fabric pocket			○
Rear of backrest upholstered in fabric			○
Anti-vandalism backrest (backrest completely covered in robust plastic shell)	●	●	●
Backrest in short and narrow design			○
Backrest in medium and extra narrow design			○
Backrest in medium and narrow design			●
Backrest in medium and wide design			○
Backrest in long and narrow design			n.a.
Armrest and grab handles			
Armrest or arm support on the aisle side	○		n.a.
Folding armrest on the aisle side	○		●
Middle armrest between the seats			○
Armrest on the wall side	○		○
Cover	○		
Grab handle			●
Tables			
Small folding table with cupholder			●
Mobile phone holder			○
Table			○
Additional parts			
Bag hook with integrated grab handle			●
USB socket	○		○
Footrest			○
Upholstery			
Headrest cover			○
Premium-comfort head section			○
Fabric edging			○
Basic upholstery	●		●
Luxline upholstery			○
Comfort upholstery variants	○		○
Design			
Seat numbering - numbers			●
Seat numbering - letters			○
Premium-comfort headrest			○

- Standard
- Optional

Subject to technical changes

PRODUCT OVERVIEW

Basic Features	INNERCITY3000
Seat shell	●
Grap handle	●
Top Cover	○
Hip support	○
Armrest	○
Pole holder	○
Pure plastic seat version (plastic pads)	○
Seat cushion high (padded)	●
Seat cushion low (non-padded)	○
Leather upholstery	○
Branding	○
USB ports	○
Integrated lights	○
Signal functions	○

Basic Features	PREMIUM3000
General	
Seat surface width 500 mm	●
Armrest width 60 mm	●
Artificial leather upholstery, rhombic design	●
2-point-belt	●
Adjustable backrest, electric leg support	●
Height-adjustable headrest with adjustable side contours	●
Table under armrest	●
Socket 22V + USB	●
Storage bag for magazines	●
Reading lamp	●
Seat foot	●
Control panel	●
OPTIONAL FEATURES	
Tablet holder	○
Seat heating	○
Massage function	○

- Standard
- Optional

Subject to technical changes