



# ROADTIGER® LUXURY

The premium model



red dot award 2019  
winner



**CAPITAL**seating

[www.capitalseating.co.uk](http://www.capitalseating.co.uk)

tel: +44 (0)116 216 9910 | email: [grammer@capitalseating.co.uk](mailto:grammer@capitalseating.co.uk)



**GRAMMER**

# TECHNICAL DATA

## ROADTIGER® LUXURY



Pneumatic suspension

### The premium model

The ROADTIGER Luxury is a seat in a class of its own. It is upholstered in a luxury high-quality leather. With the active climate system the driver remains comfortable at all temperatures. A further special feature is the adjustable side support for the backrest and the seat cushion, ensuring that the seat can be set to individual driver's needs.



Automatic weight adjustment



Pneumatic lumbar support



Adjustable shock absorber



Fore/aft adjustment



Active climate system



Seat heating 2 steps



Adjustable side support



Shoulder adjustment



Adjustable seatbelt height



Tunnel-side backrest release

**Features** ● Standard ○ Optional

|   | ROADTIGER® LUXURY left/right |
|---|------------------------------|
| Pneumatic suspension                    | ●                            |
| ① Shock absorber adjustable in 4 steps  | ●                            |
| Suspension stroke 55 mm                 | ●                            |
| ② Height adjustment 145 mm              | ●                            |
| Automatic weight adjustment 50 - 190 kg | ●                            |
| ③ Fore/aft adjustment 220 - 250 mm *    | ●                            |
| ④ Quick down                            | ●                            |
| ⑤ Fore/aft isolator 25 mm               | ●                            |
| ⑥ Tilt adjustment                       | ●                            |
| ⑦ Integrated headrest                   | ●                            |
| ⑧ Adjustable backrest angle             | ●                            |
| ⑨ Tunnel-side backrest release          | ●                            |
| ⑩ Pneumatic shoulder adjustment         | ●                            |

|   | ROADTIGER® LUXURY left/right |
|---|------------------------------|
| ⑪ Pneumatic lumbar support                          | ●                            |
| ⑫ Adjustable side support backrest and seat cushion | ●                            |
| ⑬ Adjustable seat cushion depth 60 mm in 6 steps    | ●                            |
| ⑭ Seat heating                                      | ●                            |
| ⑮ Active climate system                             | ●                            |
| ⑯ Integrated 3-point belt                           | ●                            |
| ⑰ Belt height adjustment 60 mm in 3 steps           | ●                            |
| Buckle warning contact                              | ●                            |
| Seat belt pretensioner                              | ●                            |
| Upholstery leather                                  | ●                            |
| <b>OPTIONAL FEATURES</b>                            |                              |
| ⑱ Comfortable armrests, tiltable                    | ○                            |
| Comfortable armrests, tiltable, covered in leather  | ○                            |

### Measurements (installation dimensions)

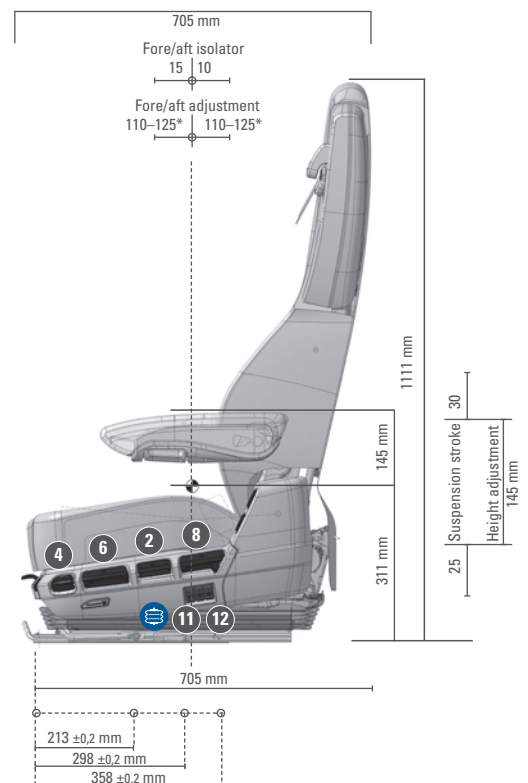
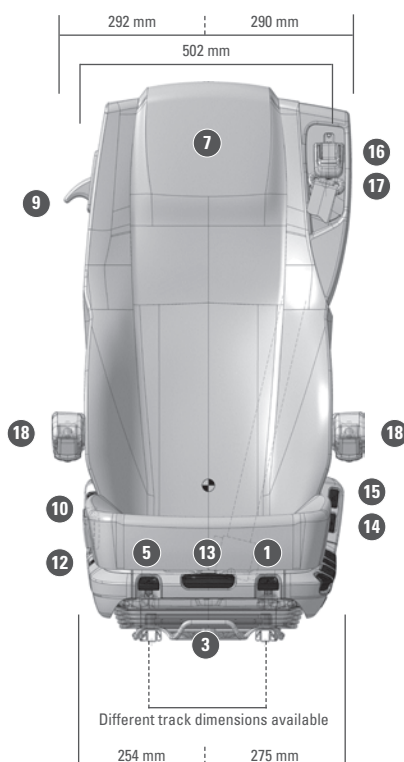

\* Depending on the version

All dimensions in mm.  
Subject to technical changes.