



# ROADTIGER® COMFORT

The comfort model



red dot award 2019  
winner



**CAPITAL**seating

[www.capitalseating.co.uk](http://www.capitalseating.co.uk)

tel: +44 (0)116 216 9910 | email: [grammer@capitalseating.co.uk](mailto:grammer@capitalseating.co.uk)



**GRAMMER**

# TECHNICAL DATA

## ROADTIGER® COMFORT



Pneumatic suspension

### The comfort model

The ROADTIGER Comfort offers additional features to make the driver's journey that much more pleasant. The passive climate system and seat heating ensure wellbeing in all temperatures. Thanks to the shoulder adjustment, the adjustable side support in the backrest and the 3-step seat belt height adjustment the seat can be made to fit the driver even more perfectly.



Automatic weight adjustment



Pneumatic lumbar support



Adjustable shock absorber



Fore/aft adjustment



Passive climate system



Seat heating 2 steps



Adjustable side support



Shoulder adjustment



Adjustable seatbelt height



Tunnel-side backrest release

**Features** ● Standard ○ Optional

	ROADTIGER® COMFORT left/right
Pneumatic suspension	●
① Shock absorber adjustable in 4 steps	●
Suspension stroke 55 mm	●
② Height adjustment 145 mm	●
Automatic weight adjustment 50 - 190 kg	●
③ Fore/aft adjustment 220 - 250 mm*	●
④ Quick down	●
⑤ Fore/aft isolator 25 mm	●
⑥ Tilt adjustment	●
⑦ Integrated headrest	●
⑧ Adjustable backrest angle	●
⑨ Tunnel-side backrest release	●
⑩ Pneumatic shoulder adjustment	●

	ROADTIGER® COMFORT left/right
⑪ Pneumatic lumbar support	●
⑫ Adjustable side support, backrest	●
⑬ Adjustable seat cushion depth, 60 mm in 6 steps	●
Passive climate system	●
⑭ Seat heating 2 steps	●
⑮ Integrated 3-point belt	●
⑯ Belt height adjustment, 60 mm in 3 steps	●
Buckle warning contact	●
Seat belt pretensioner	●
Upholstery fabric	●
OPTIONAL FEATURES	
⑰ Comfortable armrests, tiltable	○
Comfortable armrests, tiltable, covered in fabric	○

### Measurements (installation dimensions)

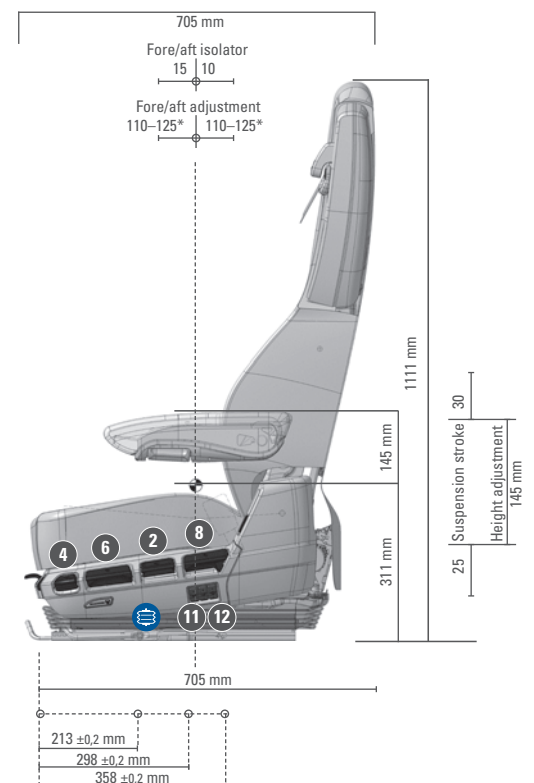
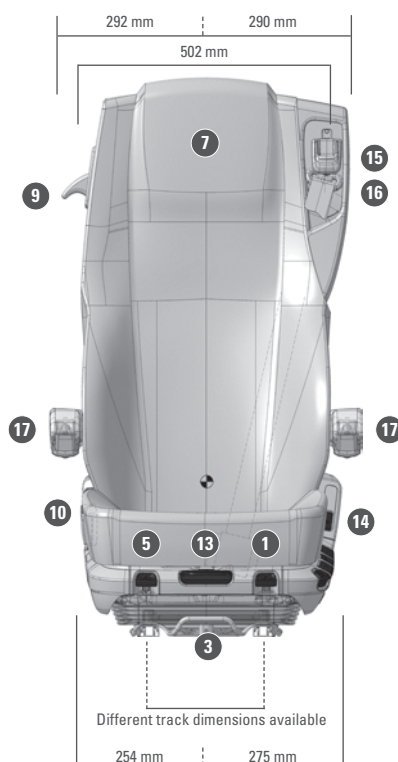

\* Depending on the version

All dimensions in mm.  
Subject to technical changes.